



# 96 Hinge

Lift-off · In-line · Zinc

- Allows for quick, easy door removal
- Door can also be permanently installed

### Material and Finish

Zinc alloy, black powder coated

### Performance Details

	Radial Load	Axial Load
Max. static load	1300 N (300 lbf)	2200 N (500 lbf)
Average ultimate load	3300 N (750 lbf)	9300 N (2100 lbf)

### Installation Notes

Screws not supplied.

Max. tightening torque of screw:  
8.5 N·m (75 in·lbf)

Calculate screw length using the following formula:

Door thickness + 5 (.200)

In-line mount preparation:

To allow for 180° rotation R or S must be < 25.4 (1.00).

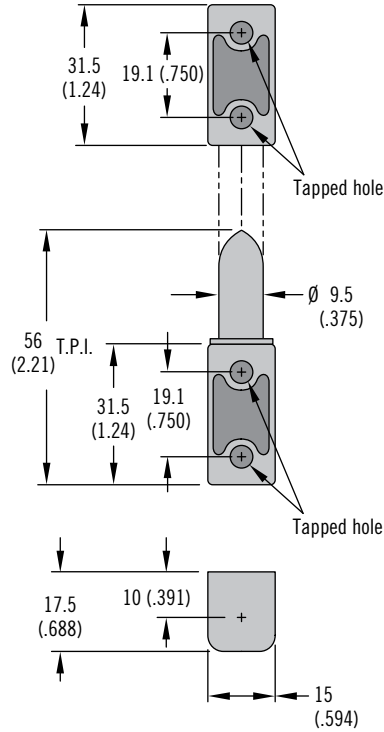

For Lift-Off Mounting

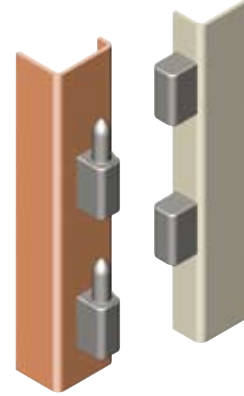

For Non Lift-Off Mounting

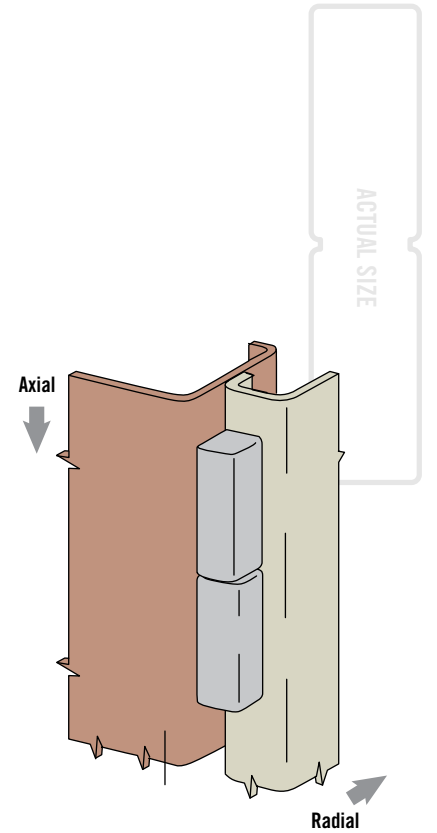
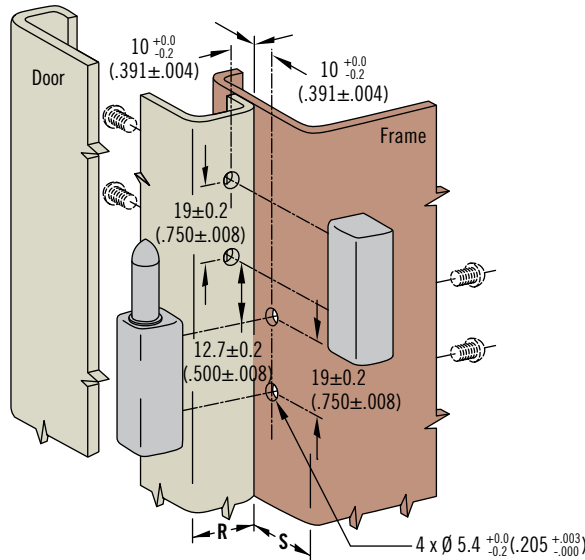
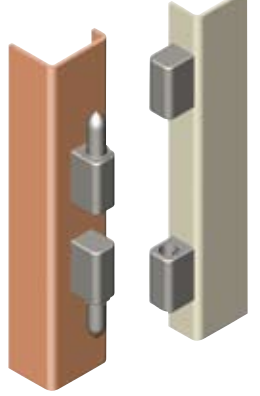

### Part Number

See Table

Tapped Hole	Part Number
Imperial 10-32	96-10-500-50
Metric M5 x 0.8	96-50-500-50

Dimensions in millimeters (inch) unless otherwise stated



[www.southco.com/96](http://www.southco.com/96)

# 96 Hinge

Lift-off · Offset · Zinc



## Type B

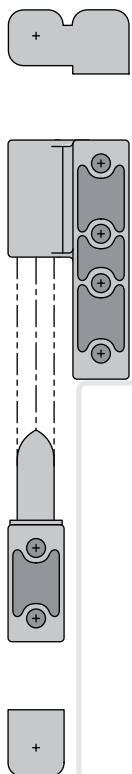

## Type A

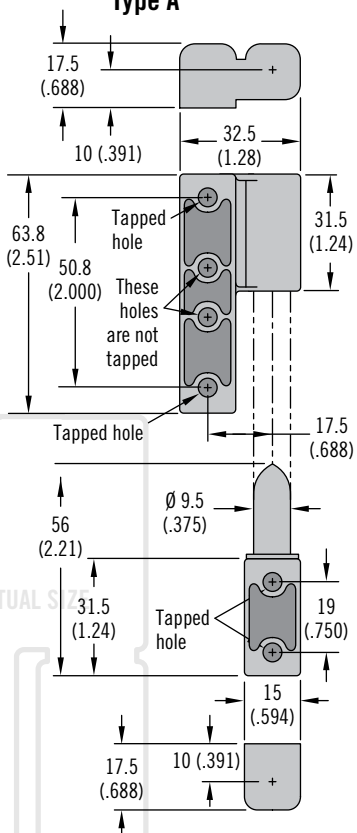

## For Lift-Off Mounting

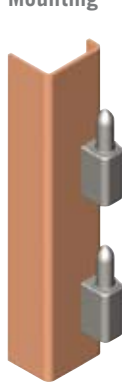

## For Non Lift-Off Mounting

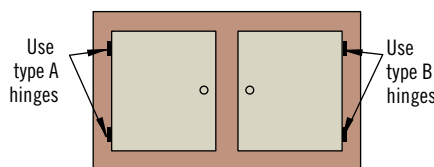
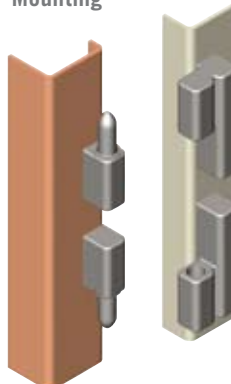

- Allows for quick, easy door removal
- Door can also be permanently installed

## Material and Finish

Zinc alloy, black powder coated

## Performance Details

	Radial Load	Axial Load
Max. static load	1300 N (300 lbf)	2200 N (500 lbf)
Average ultimate load	3300 N (750 lbf)	9300 N (2100 lbf)

## Installation Notes

Screws not supplied.

Max. tightening torque of screw:  
8.5 N·m (75 in·lbf)

Calculate screw length using the following formula:

Door thickness + 10 (.400)

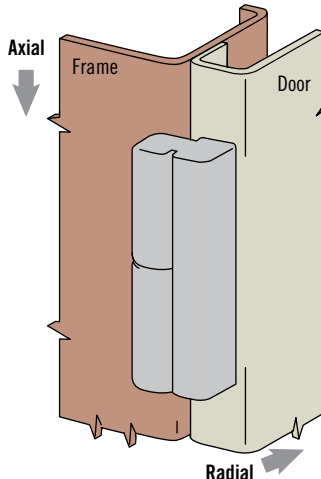
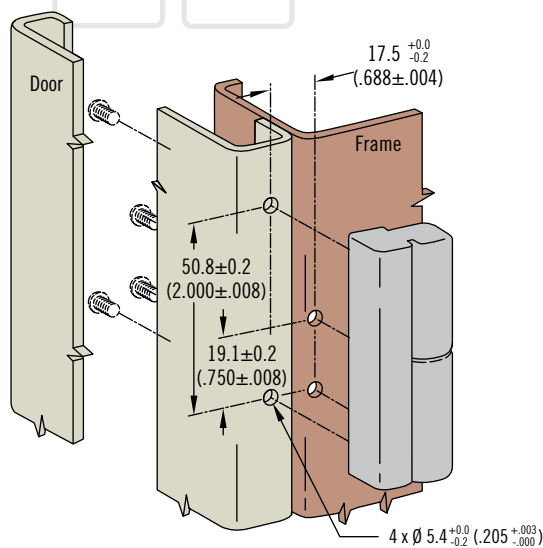

Tapped Hole	Part Number	
	Type A	Type B
Imperial 10-32	96-10-510-50	96-10-520-50
Metric M5 x 0.8	96-50-510-50	96-50-520-50

## Part Number

See table



# 96 Hinge

Lift-off · In-line · Zinc and stainless steel

- Allows for quick, easy door removal
- Door can also be permanently installed

## Material and Finish

Zinc alloy, chrome plated, powder coated or stainless steel

## Performance Details

Radial load

Max. static load:

Zinc alloy: 1300 N (300 lbf)

Stainless steel: 3000 N (670 lbf)

Axial Load

Max. static load:

Zinc alloy: 2200 N (500 lbf)

Stainless steel: 5000 N (1120 lbf)

## Installation Notes

Screws not supplied.

Attach hinge with four M5 x 0.8

Max. screw length = door

(or frame) thickness + 10 (.400)

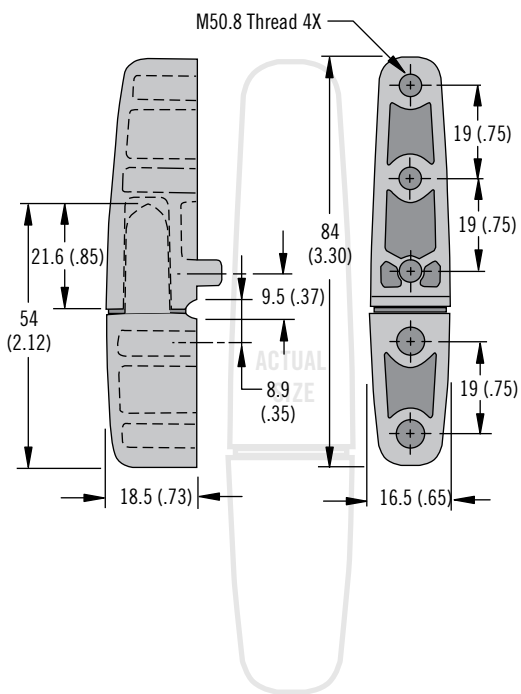

For Lift-Off Mounting

For Non Lift-Off Mounting

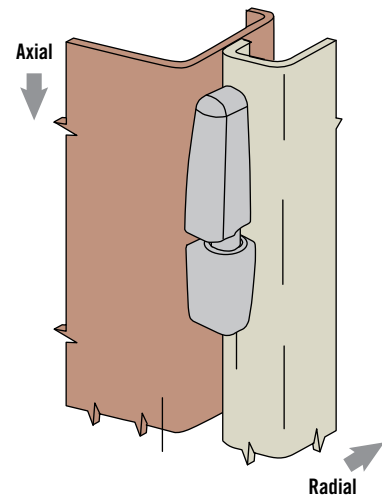
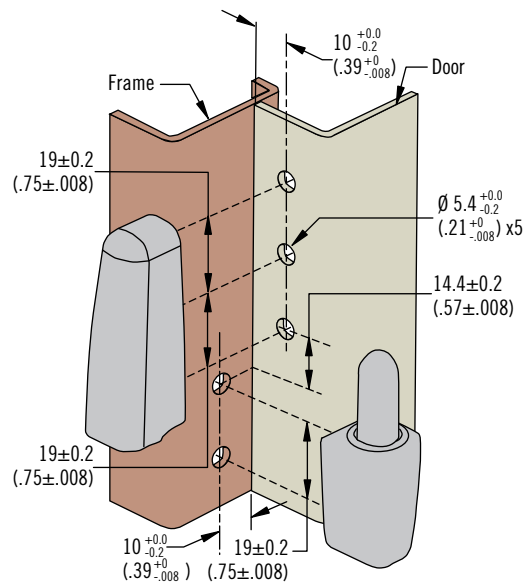
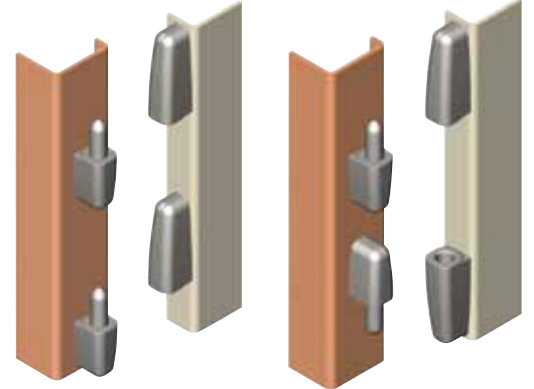

## Part Number

See table

Material & Finish	Part Number
Zinc alloy, bright chrome	96-MA-80-10
Zinc alloy, black powder coated	96-MA-80-50
Zinc alloy, satin chrome	96-MA-80-20
Stainless steel, polished	96-MA-80-24

Dimensions in millimeters (inch) unless otherwise stated



[www.southco.com/96](http://www.southco.com/96)

**southco**<sup>®</sup>  
CONNECT · CREATE · INNOVATE

# 96 Hinge

Lift-off · Offset · Zinc and stainless steel



**Type A**

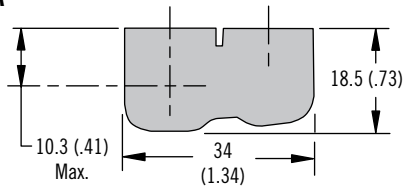

**Type B**

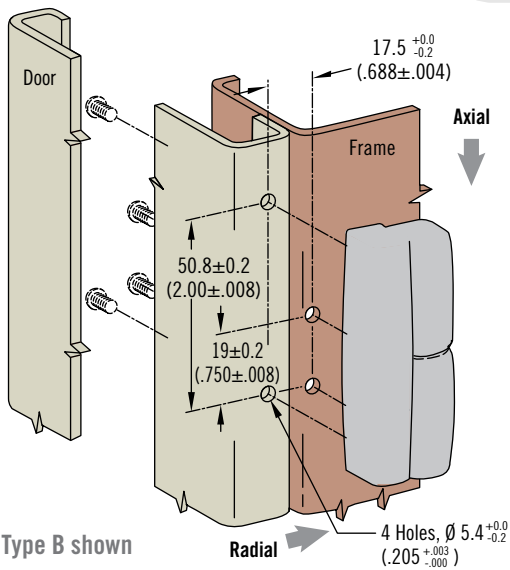
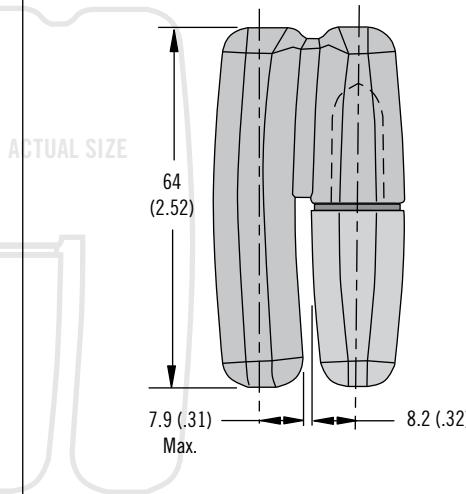
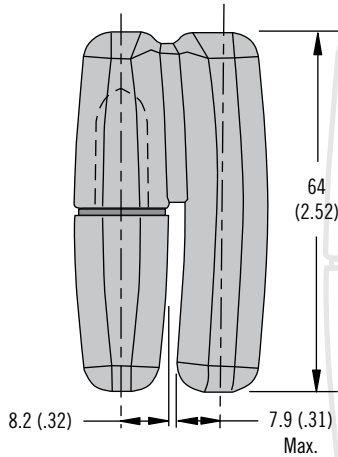
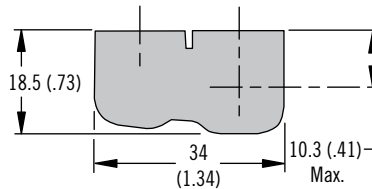

**Type B shown**

**For Lift-Off Mounting**

**For Non Lift-Off Mounting**

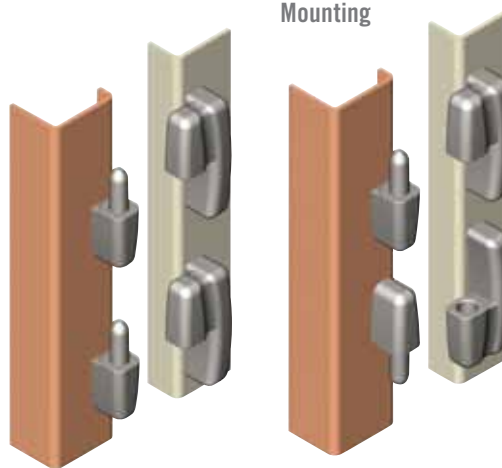

Use type A hinges

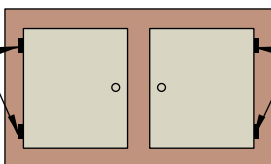

Use type B hinges

- Allows for quick, easy door removal
- Door can also be permanently installed

**Material and Finish**

Zinc alloy, chrome plated, powder coated or stainless steel

**Performance Details**

Radial load

Max. static load:

Zinc alloy: 1300 N (300 lbf)

Stainless steel: 3000 N (670 lbf)

Axial Load

Max. static load:

Zinc alloy: 2200 N (500 lbf)

Stainless steel: 5000 N (1120 lbf)

**Installation Notes**

Screws not supplied.

Attach hinge with four M5 x 0.8  
Max. screw length = door (or frame) thickness + 10 (.400)



# 96 Hinge

Lift-off · In-line · Offset · Plastic

- Allows for quick, easy door removal
- Corrosion-resistant materials
- Door can also be permanently installed

### Material and Finish

Glass reinforced nylon, black

### Performance Details

300 Series	Radial Load	Axial Load
Max. static load	670 N (150 lbf)	1560 N (350 lbf)
Average ultimate load	1100 N (250 lbf)	2500 N (550 lbf)

400 Series	Radial Load	Axial Load
Max. static load	1000 N (225 lbf)	2000 N (450 lbf)
Average ultimate load	1900 N (425 lbf)	4900 N (1100 lbf)

### In-Line Knuckle Style

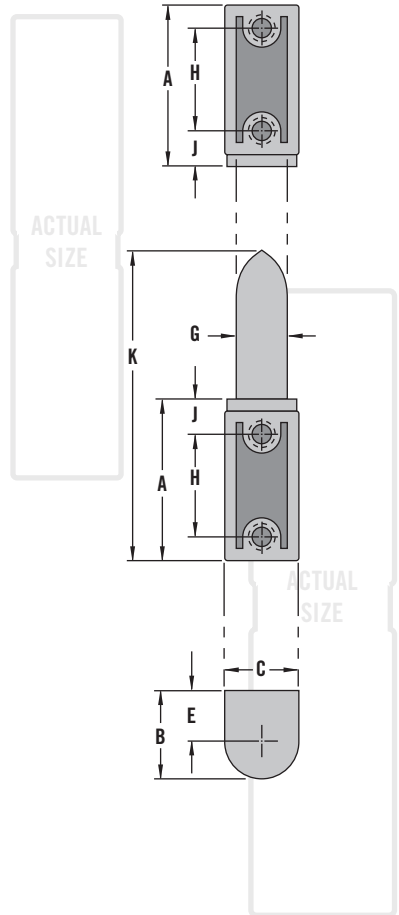

### Offset Knuckle Style

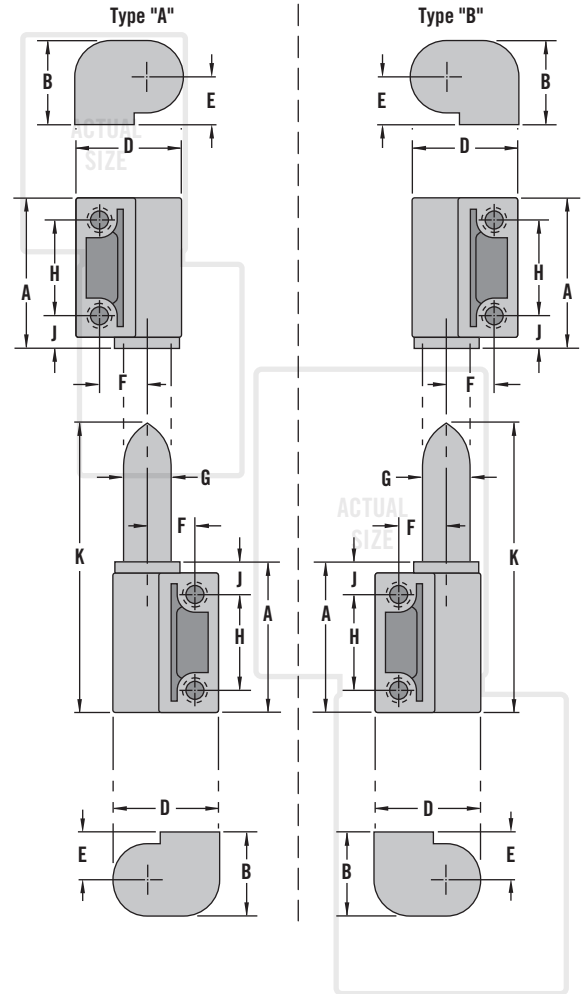

### Mounting variations

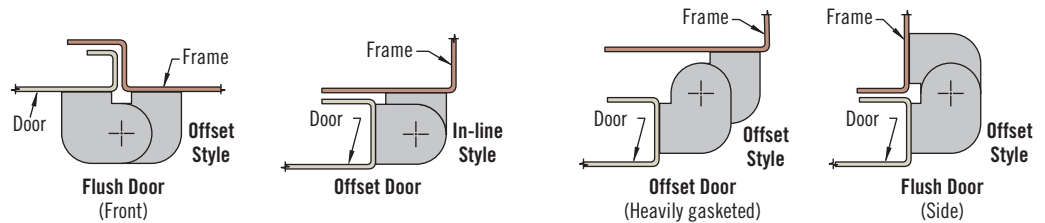

### Part Number

See table

Series	Tapped Hole	Dimensions								Part Number		
		A	B	C	D	E, F & G	H	J	K	In-Line Knuckle Style	Offset Knuckle Style	
		Type "A"	Type "B"									
300	M5	31	16.7	14.3	21.5	9.5	19	7	58	96-50-300-11	96-50-310-11	96-50-320-11
	10-24	(1.22)	(.66)	(.56)	(.84)	(.38)	(.75)	(.28)	(2.28)	96-10-300-11	96-10-310-11	96-10-320-11
400	M6	41.3	22.2	19	28.5	12.7	25.5	9.5	78	96-50-400-11	96-50-410-11	96-50-420-11
	1/4-20	(1.63)	(.88)	(.75)	(1.13)	(.50)	(1.00)	(.38)	(3.06)	96-10-400-11	96-10-410-11	96-10-420-11

Dimensions in millimeters (inch) unless otherwise stated



[www.southco.com/96](http://www.southco.com/96)

### In-Line Knuckle Style

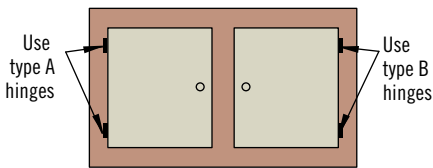
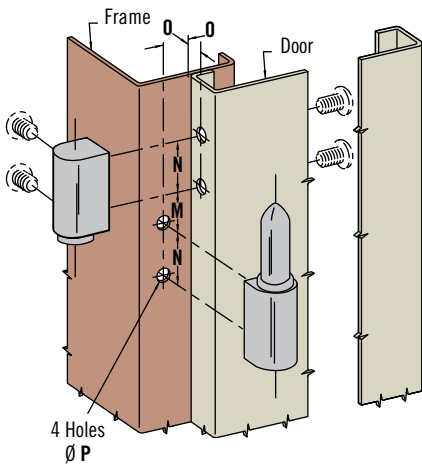
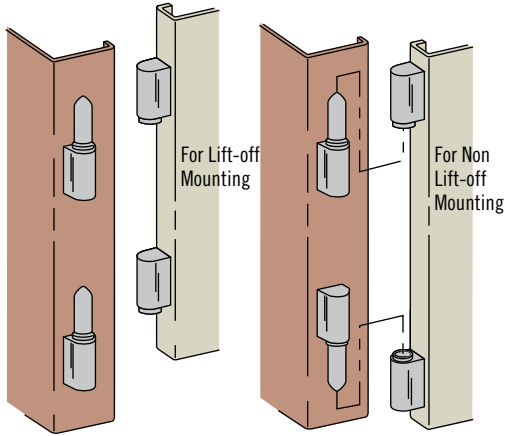

### Offset Knuckle Style

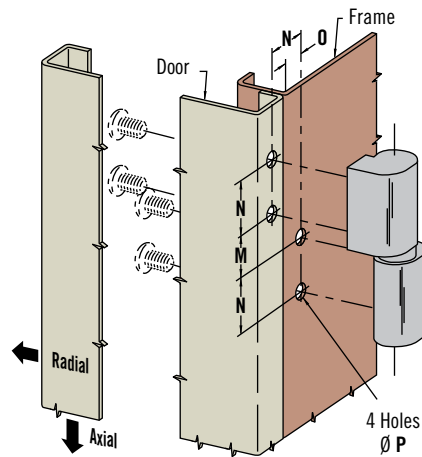
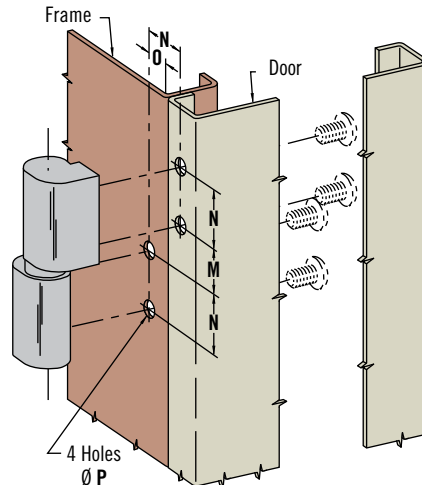
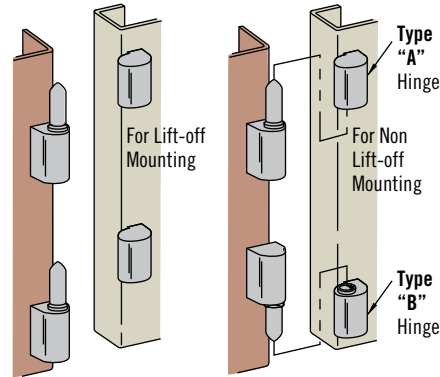

### Installation Notes

Screws not supplied  
 Max. tightening torque of screw:  
 2.8 N·m (25 in·lbf)

Calculate screw length using the following formula:  
 Door thickness + adjustment value

Series	Adjustment Value	
	In-Line	Offset
300	4.8 (.19)	6.5 (.25) Min. to 9.5 (.38) Max.
400	6.4 (.25)	9.5 (.38) Min. to 12.7 (.50) Max.

Series	Installation Dimensions			
	M	N	O	P
300	14.3 <sup>+0.0</sup> <sub>-0.3</sub> (.563±.008)	19 <sup>+0.2</sup> <sub>-0.1</sub> (.750±.008)	9.5 <sup>+0.3</sup> <sub>-0.1</sub> (.375±.005)	5.4 <sup>+0.1</sup> <sub>-0.0</sub> (.205 <sup>+0.03</sup> <sub>-0.000</sub> )
400	19.0 <sup>+0.0</sup> <sub>-0.3</sub> (.750±.008)	25.5 <sup>+0.1</sup> <sub>-0.2</sub> (1.000±.008)	12.7 <sup>+0.2</sup> <sub>-0.1</sub> (.500±.005)	6.7 <sup>+0.1</sup> <sub>-0.0</sub> (.264 <sup>+0.03</sup> <sub>-0.000</sub> )



# 96 Hinge

Lift-off · In-line · Plastic

- Allows for quick, easy door removal
- Door can also be permanently installed

### Material and Finish

Black: Glass reinforced nylon  
 Chrome: PC/ABS blend, chrome

### Performance Details

Black	Radial Load	Axial Load
Max. static load	700 N (155 lbf)	1200 N (270 lbf)
Average Ultimate load	1000 N (224 lbf)	3500 N (785 lbf)

Chrome	Radial load	Axial load
Max. static load	350 N (79 lbf)	900 N (202 lbf)
Average ultimate load	600 N (135 lbf)	2200 N (495 lbf)

### Installation Notes

Recommended tightening torque for mounting screws:  
 1.6 N·m (14 in·lbf)

Offset mount preparation:  
 To allow for 180° rotation A or B must be 8.5± (.33±.04)

### Part Number

See table

Order pin, receiver and screws separately

### Receiver

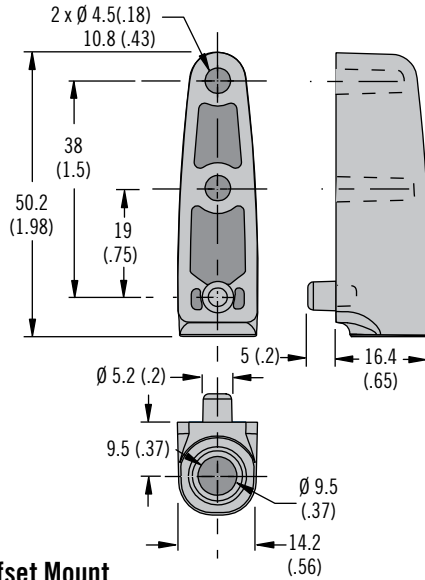

### Offset Mount

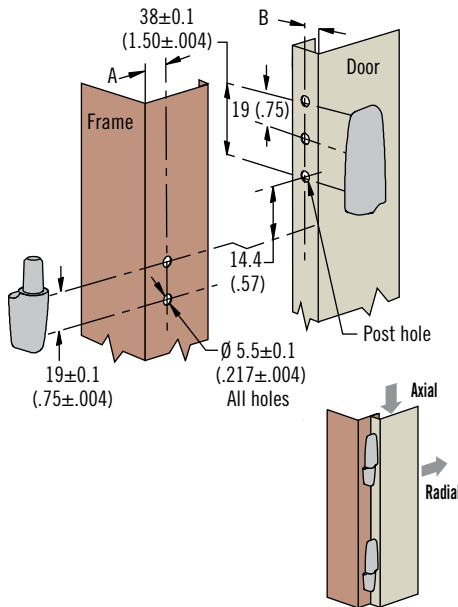

### Pin

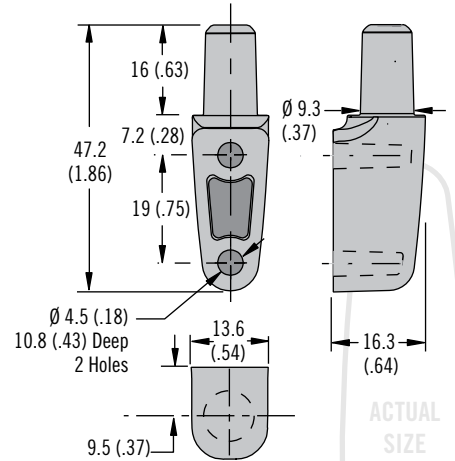

### Flush Mount

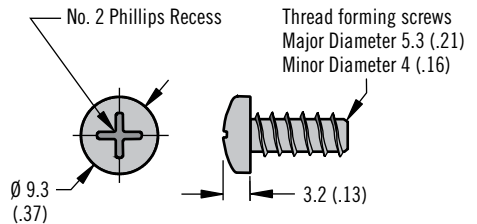
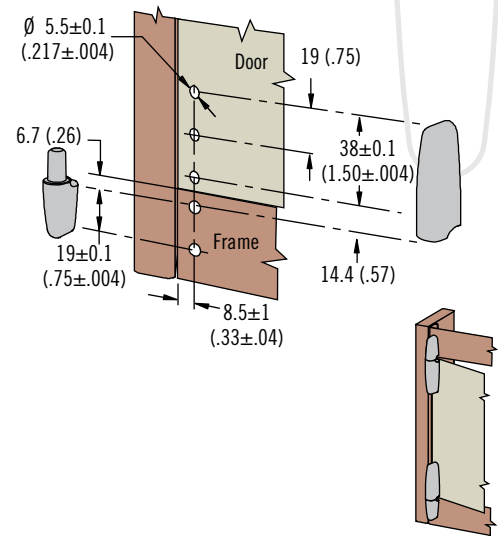

Door Thickness	Part Number
	Screws (4 per bag)
1 - 4 (.04 - .16)	96-79-1
4 - 7 (.16 - .28)	96-79-2
7 - 10 (.28 - .39)	96-79-3
10 - 13 (.39 - .51)	96-79-4

Finish	Part Number	
	Pin	Receiver
Black	96-710	96-720
Chrome	96-711	96-721

Dimensions in millimeters (inch) unless otherwise stated

# 96 Hinge

Lift-off · Adjustable compression · In-line · Zinc



## Front Mount

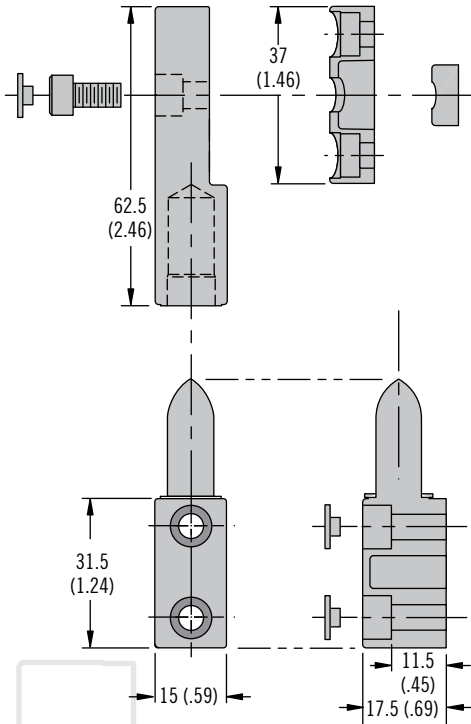

## Concealed Mount

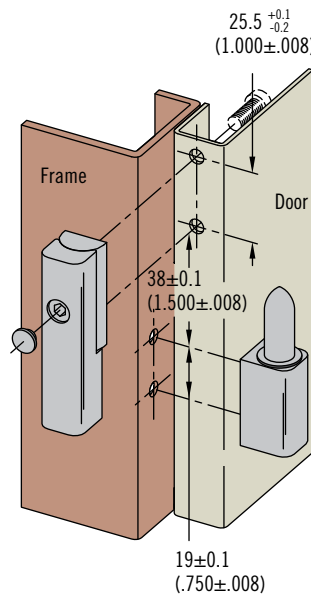
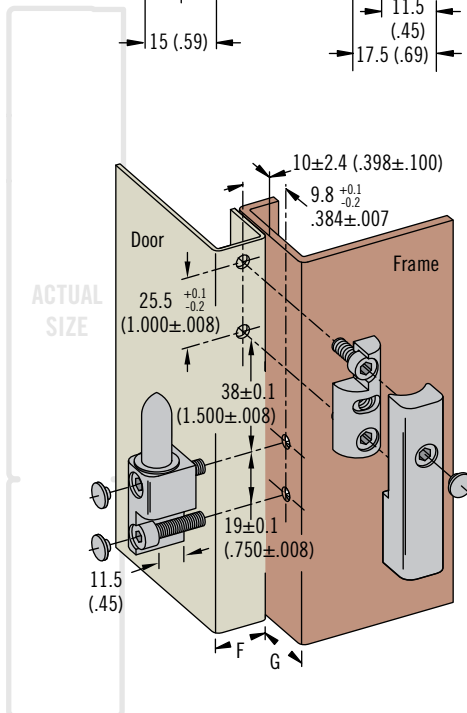
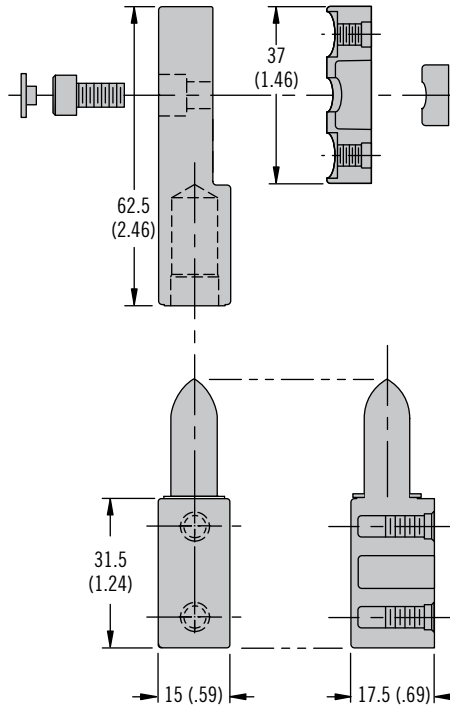

- Adjusts to ensure gasket compression
- Allows for quick, easy door removal



## Material and Finish

Zinc alloy, black powder coated

## Installation Notes

Screws not supplied.

Max. screw length equals door or frame thickness plus 7.5 (.30)

## Performance Details

	Radial Load	Axial Load
Max. static load	1000 N (255 lbf)	2220 N (500 lbf)
Average ultimate load	1550 N (350 lbf)	14,000 N (3200 lbf)

## Notes

Hinges provide 5 (.20) of total adjustment

Either F Dimension or G dimension must be less than 19.8 (.78) for the door to open a full 180°

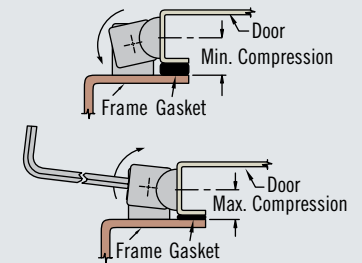

Install Style	Tapped Hole	Part Number
Front mount	Thru hole	96-10-572
Concealed mount	10-32 Imperial	96-10-570
	M5 x 0.8 Metric	96-50-570

## Part Number

See table





# 96 Hinge

Lift-off · In-line · Zinc

- Allows for quick, easy door removal
- Concealed installation

## Material and Finish

Zinc alloy, black powder coated

## Performance Details

	Radial Load	Axial Load
Max. static load	1100 N (250 lbf)	1250 N (280 lbf)
Average ultimate load	2400 N (530 lbf)	2600 N (580 lbf)

## Installation Notes

Screws not supplied.

Recommended tightening torque for mounting screws:

1.1 N·m (10 in·lbf)

Calculate screw length using the following formula:

Door / frame thickness +5 (.20)

## In-Line

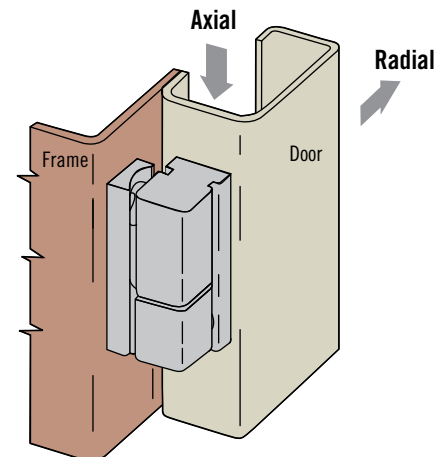
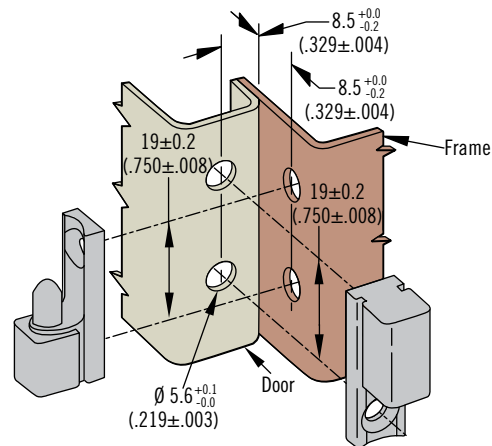
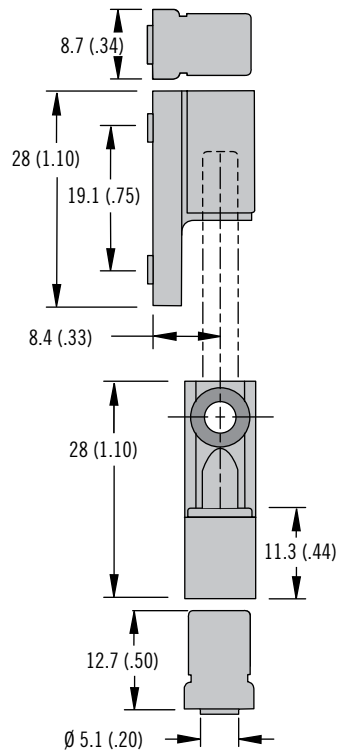

## Part Number

See table

Tapped Hole	Part Number
Imperial 6-32	96-110
Metric M4 x 0.7	96-140

Dimensions in millimeters (inch) unless otherwise stated



[www.southco.com/96](http://www.southco.com/96)

**southco**  
CONNECT · CREATE · INNOVATE

# 96 Hinge

Lift-off · Offset · Zinc



## Offset Type A

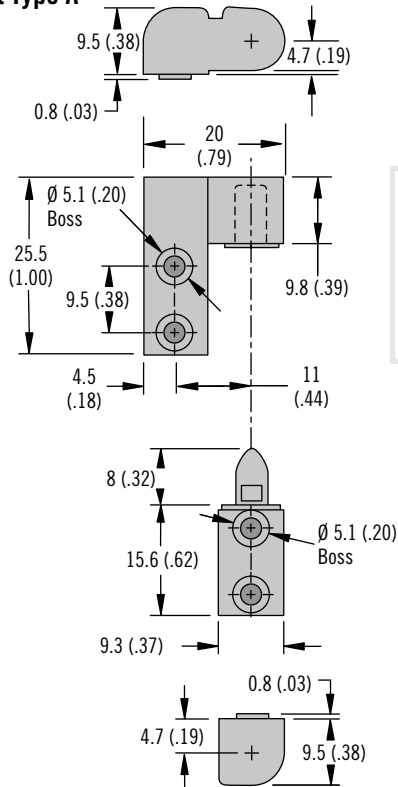

## Offset Type B

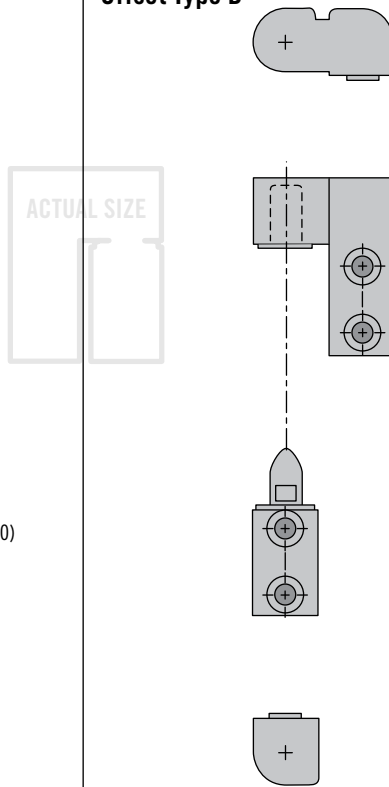

ACTUAL SIZE

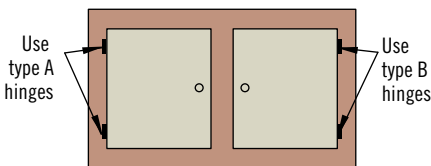
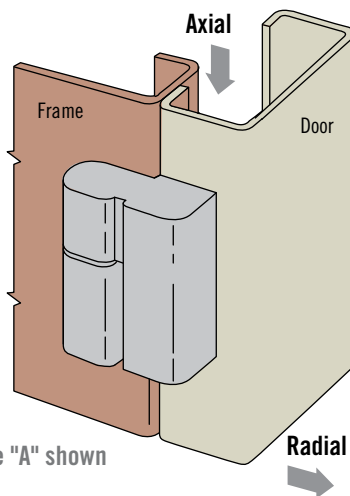
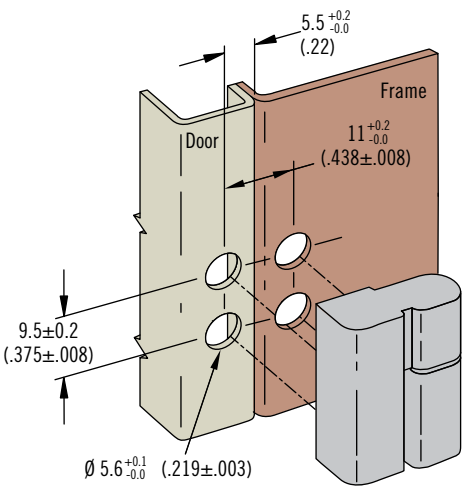

- Allows for quick, easy door removal
- Door can also be permanently installed

### Material and Finish

Zinc alloy, black powder coated

### Performance Details

	Radial Load	Axial Load
Max. static load	1100 N (250 lbf)	1250 N (280 lbf)
Average ultimate load	3300 N (750 lbf)	2600 N (580 lbf)

### Installation Notes

Screws not supplied.  
 Recommended tightening torque for mounting screws:  
 1.1 N·m (10 in·lbf)  
 Calculate screw length using the following formula:  
 Door / frame thickness + 5 (.20)

Tapped Hole	Part Number	
	Type A	Type B
Imperial 6-32	96-111	96-112
Metric M4 x 0.7	96-141	96-142

### Part Number

See table

